

Under Floor System Mounting

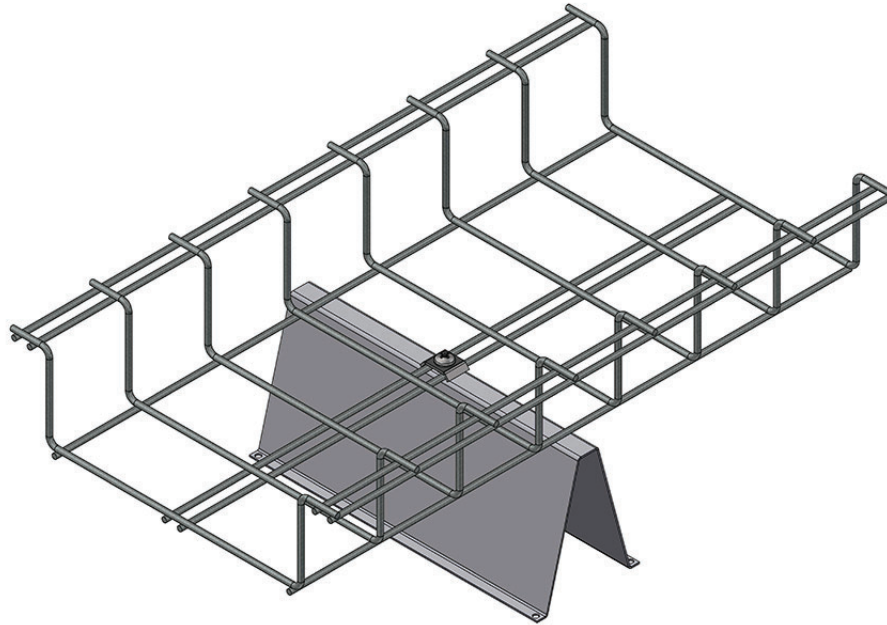

Part Number
CM 801-XX-UFS-XR

XX" = Width: 6", 8", 12", 18"
X = Rise: 2", 3", 4", 5", 6", 8", 10", 12"

*Hardware includes:

- (1) Captive Washer
- (1) 3/8" x 1.5" Carriage Bolt
- (1) 3/8" Hex Nut



SNAKE TRAY®

Snake Tray® products are covered by one or more of the following patents: #6637704, #6637165, #6463704, #6460812, #6449912, #6361000, #6347493, #6019323, #6347493, #6449912, #6460812, #5953870, #5839702, #6926236, #7168212, #7959019, #8783628, #8985530, #8622679, #9074707, #10944355, #10666029, #11205890 B2, #11271519. Foreign Patents: Australia #737813, #748160, #749488, #776643, #776644. Canada #2251732, #2319624, #2303081, #2396792. Japan #3723224. Mexico #204995, #229386, #220889. Europe #1012938, 1012937. Other Patents Pending.

CABLE MANAGEMENT, POWER DISTRIBUTION AND ENCLOSURES

291 SKIP LANE, BAY SHORE, NEW YORK 11706 USA | TEL: 800-308-6788 | 631-674-0004

Document No. MKTG-0325 | Revised January 2026 | © 2026 Snake Tray

Made in the USA