

Snake Nut™ Threaded Rod Fastener

STSN 38 (as shown)

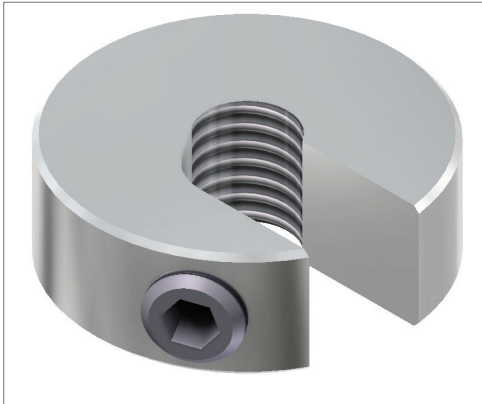

This innovative fastener eliminates the labor intensive need to hand thread hex nuts up a threaded rod. Simply insert the Snake Nut anywhere on the threaded rod and tighten into place with a set screw. Once locked into place, Snake Nut has been tested to hold up to 6,800 pounds.

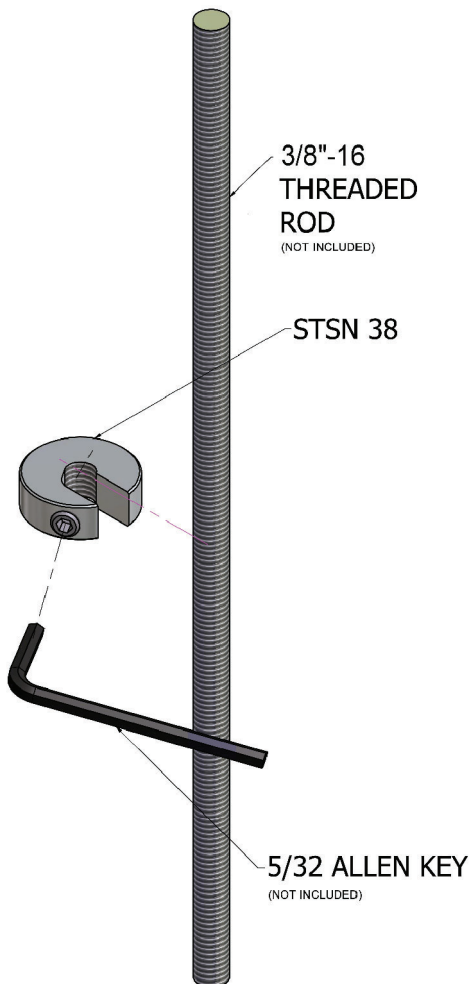
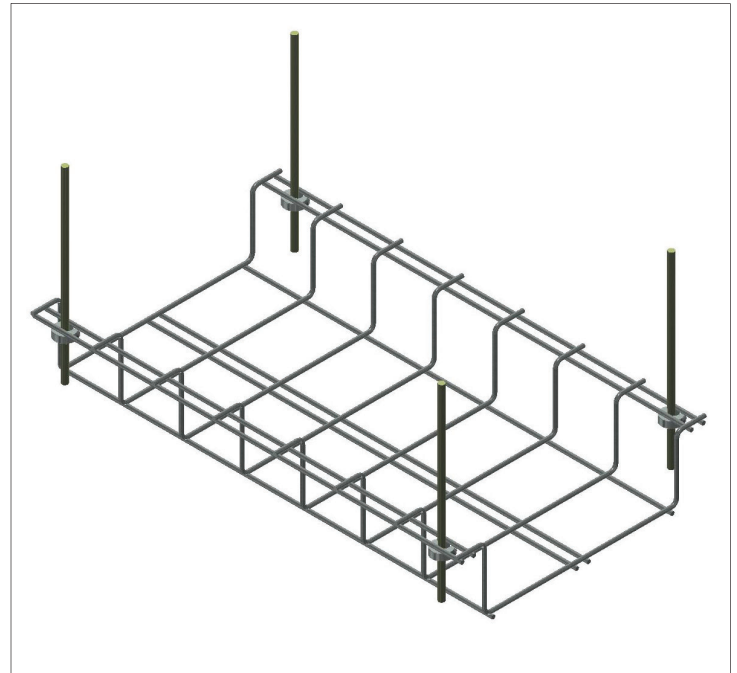

Part Number	Description
STSN 38	Fits 3/8"-16 Threaded Rod
STSN 12	Fits 1/2"-13 Threaded Rod
STSN 58	Fits 5/8"-11 Threaded Rod

Material: Steel

Finish Coat: Clear Zinc

Snake Nut™ Patent No: 8622679



SNAKE TRAY®

Snake Tray® products are covered by one or more of the following patents: #6637704, #6637165, #6463704, #6460812, #6449912, #6361000, #6347493, #6019323, #6347493, #6449912, #6460812, #5953870, #5839702, #6926236, #7168212, #7959019, #8783628, #8985530, #8622679, #9074707, #10944355, #10666029, #11205890 B2, #11271519. Foreign Patents: Australia #737813, #748160, #749488, #776643, #776644. Canada #2251732, #2319624, #2303081, #2396792. Japan #3723224. Mexico #204995, #229386, #220889. Europe #1012938, 1012937. Other Patents Pending.

CABLE MANAGEMENT, POWER DISTRIBUTION AND ENCLOSURES

291 SKIP LANE, BAY SHORE, NEW YORK 11706 USA | TEL: 800-308-6788 | 631-674-0004

Document No. MKTG-0092 | Revised August 2022 | © 2022 Snake Tray

Made in the USA