

Patch Panel Adapter

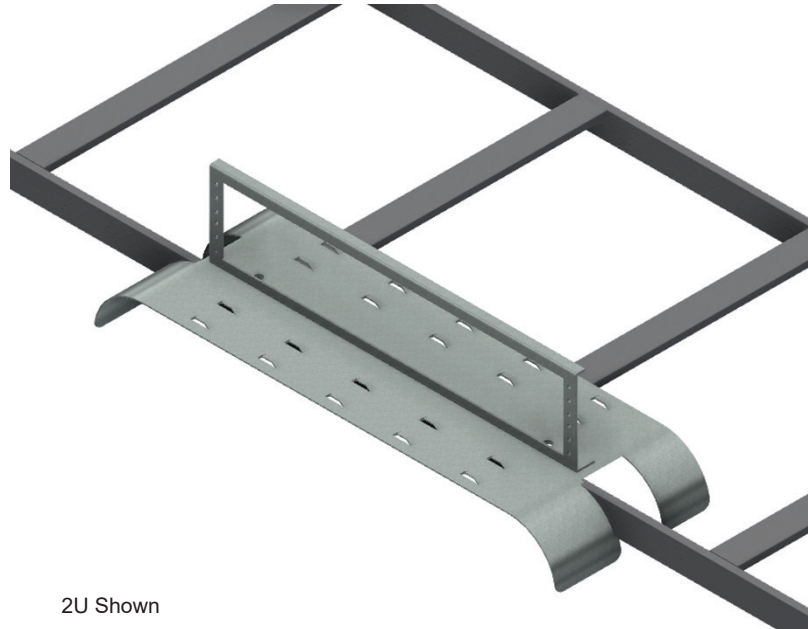

2U Shown

Part Number	Description
CM 801-PP/19-1U	19" Patch Panel Bracket - 1U
CM 801-PP/19-2U	19" Patch Panel Bracket - 2U
CM 801-PP/19-3U	19" Patch Panel Bracket - 3U
CM 801-PP/19-4U	19" Patch Panel Bracket - 4U

CUSTOM SIZES AVAILABLE.



SNAKE TRAY®

Snake Tray® products are covered by one or more of the following patents: #6637704, #6637165, #6463704, #6460812, #6449912, #6361000, #6347493, #6019323, #6347493, #6449912, #6460812, #5953870, #5839702, #6926236, #7168212, #7959019. Foreign Patents: Australia #737813, #748160, #749488, #776643, #776644. Canada #2251732, #2319624, #2303081, #2396792. Japan #3723224. Mexico #204995, #229386, #220889. Europe #1012938, 1012937. Other Patents Pending.

CABLE MANAGEMENT, POWER DISTRIBUTION AND ENCLOSURES

291 SKIP LANE, BAY SHORE, NEW YORK 11706 USA | TEL: 800-308-6788 | 631-674-0004

Document No. MKTG-0215 | Revised August 2020 | © 2020 Snake Tray

Made in the USA