

Overhead Distribution Module (Non-Powered)

CM 708-SK-0629-120 V Exhaust Fan

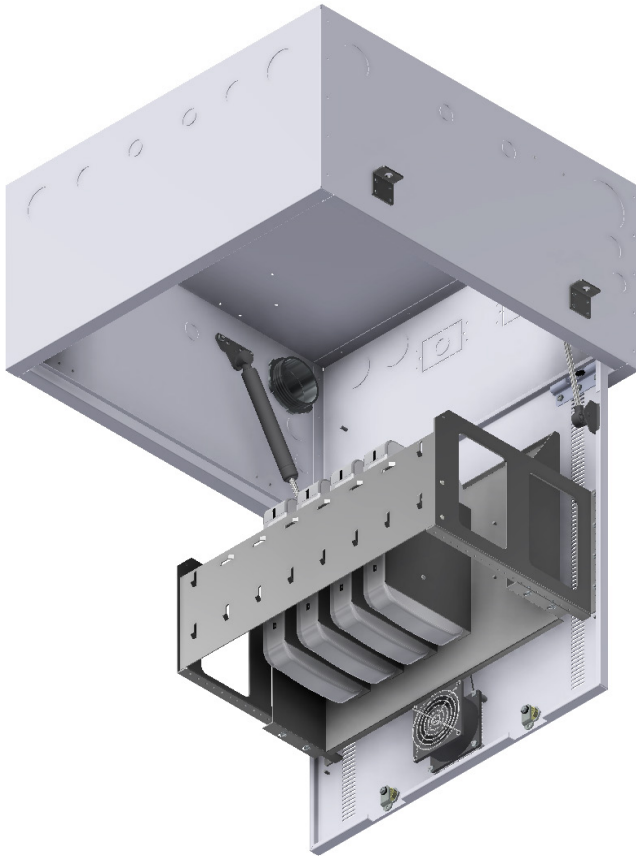

Applications:

This fully assembled ceiling mount enclosure installs in 2' x 2', 2' x 4' and 2' x 6' drop ceilings. 6 RU of standard 19" passive rack mountable space and is fitted with a horizontal cable slack manager. Door has a capacity of over 50 pounds and can be customized to user specifications to accept other component structures.

Features:

- Welded corners
- Lockable secure cover design
- Removable door mounted assembly for 19" rack mounted panels and active equipment
- Total of 6 RU rack mountable space
- Adjustable ONT Shelf
- 2 1/2" knockout for conduit
- Multiple knockout configurations available
- Cover opens safely with two built-in pneumatic cylinders
- Exhaust fan built into cover
- Constructed from 16 GA galvanized steel with customer specified powder coat finish available
- Multiple sizes available
- Four point built-in support brackets for threaded rod or hangers
- Additional bracket configurations available

Dimensions as Shown

Length	Width	Depth
24"	24"	12"



Snake Tray® products are covered by one or more of the following patents: #6637704, #6637165, #6463704, #6460812, #6449912, #6361000, #6347493, #6019323, #6347493, #6449912, #6460812, #5953870, #5839702, #6926236, #7168212, #7959019. Foreign Patents: Australia #737813, #748160, #749488, #776643, #776644. Canada #2251732, #2319624, #2303081, #2396792. Japan #3723224. Mexico #204995, #229386, #220889. Europe #1012938, 1012937. Other Patents Pending.

CABLE MANAGEMENT, POWER DISTRIBUTION AND ENCLOSURES

291 SKIP LANE, BAY SHORE, NEW YORK 11706 USA | TEL: 800-308-6788 | 631-674-0004

Document No. MKTG-0149 | Revised August 2018 | © 2018 Snake Tray

Made in the USA