

		DWG NO:		CM 708-SK-0689		
REVISION						
ZONE	REV	DESCRIPTION	ECN	DATE	APPR	ENGR
	A	INITIAL RELEASE		07/31/2018	R.J.	ER
	B	ADDED SHEET METAL SCREWS/ VELCRO BATTERY STRAP		08/17/2018	R.J.	E.R.

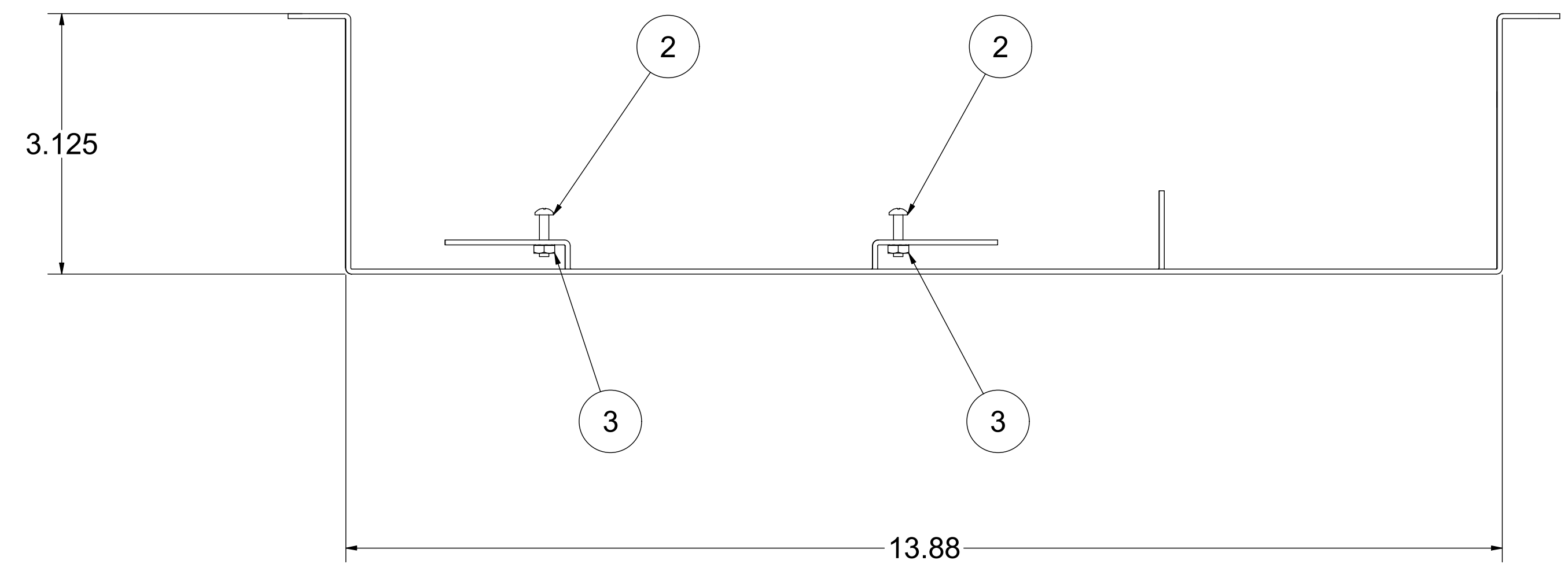
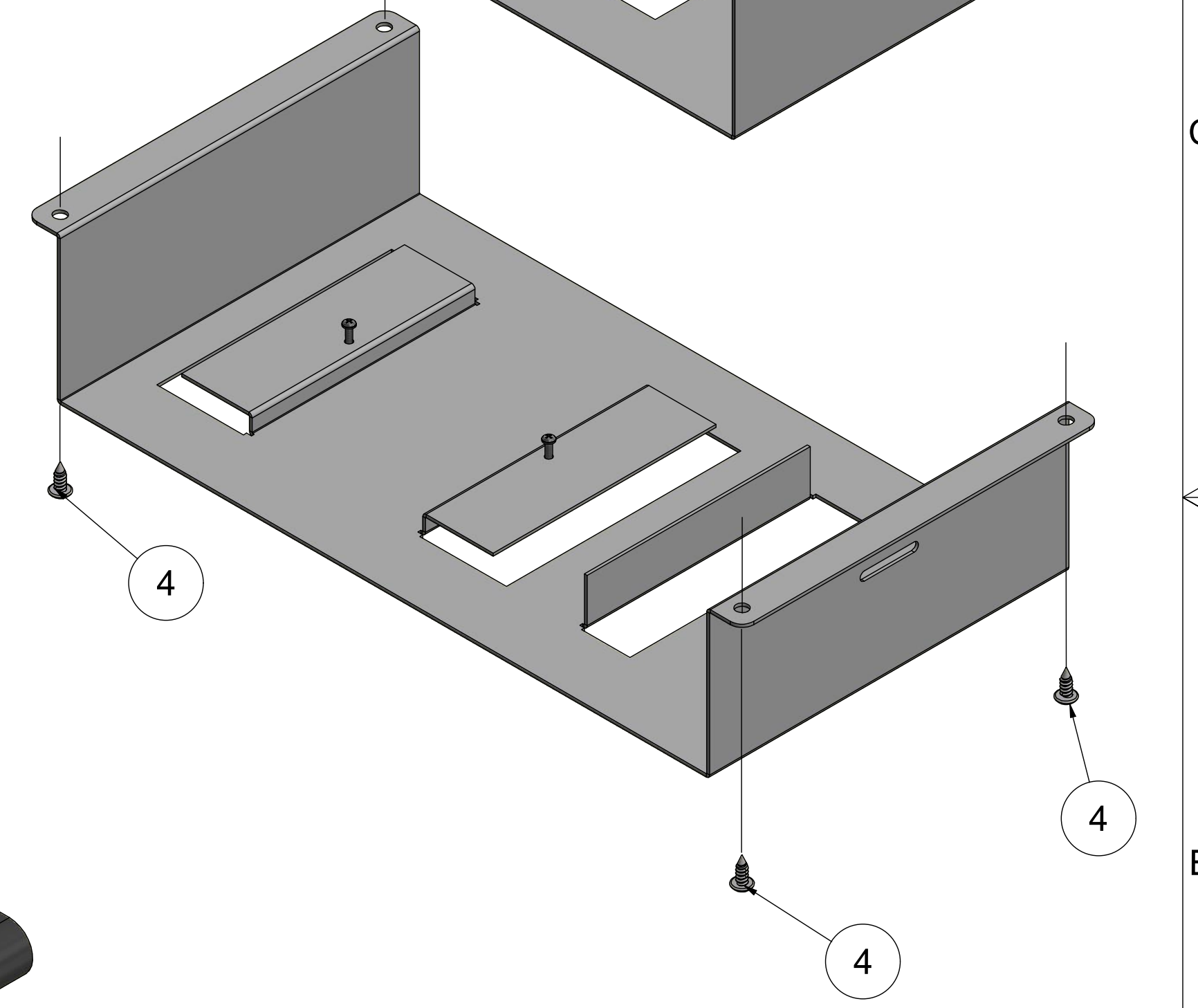
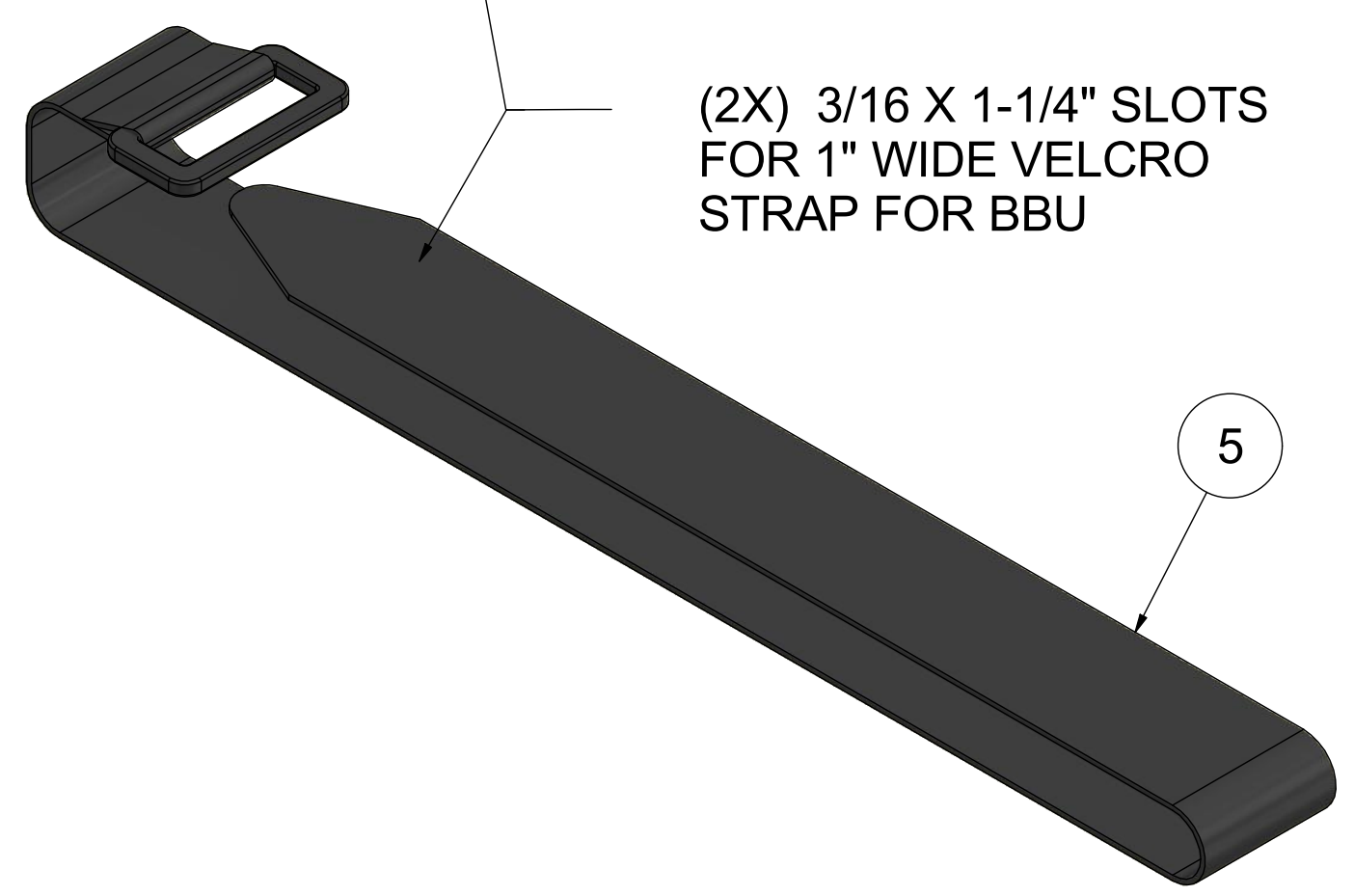
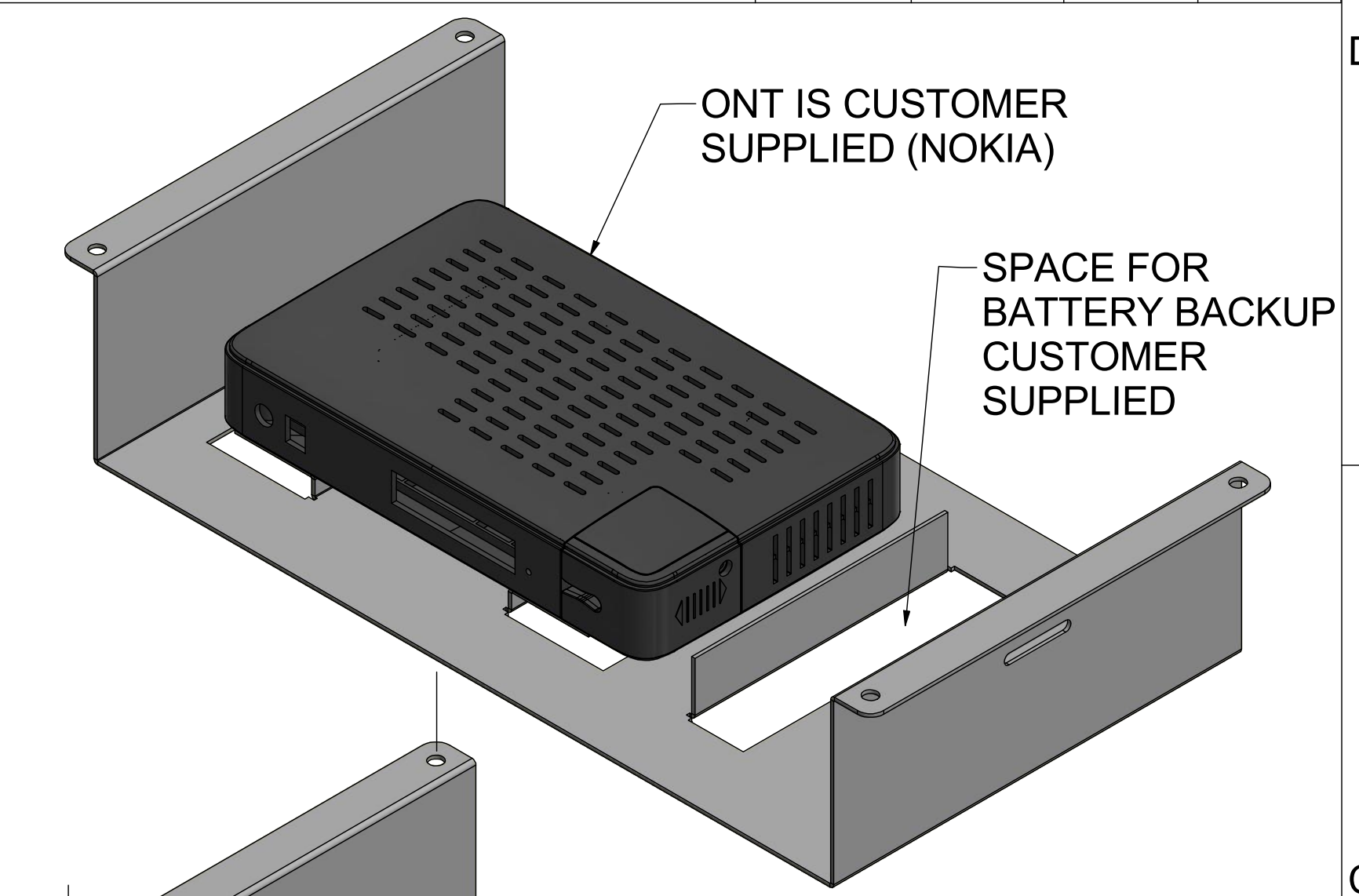
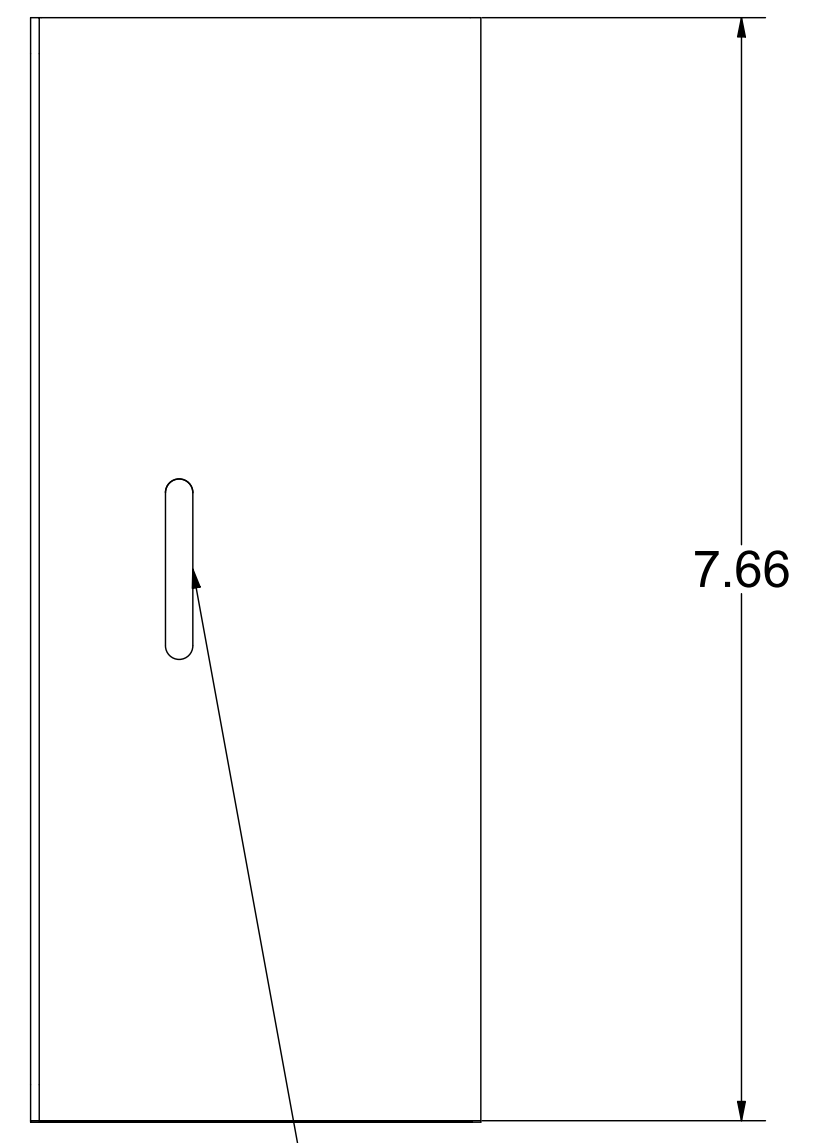
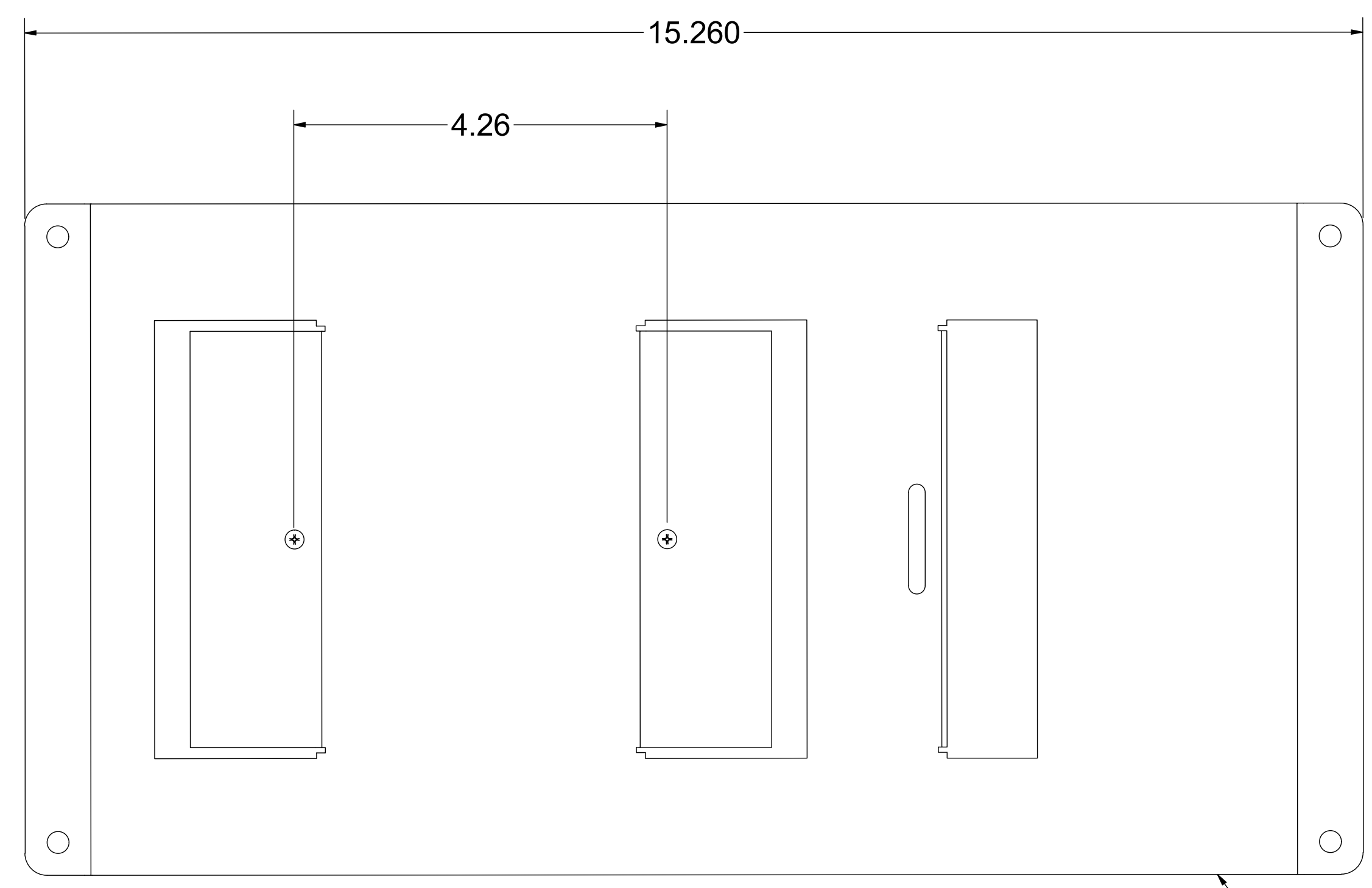

PARTS LIST			
ITEM	QTY	PART NUMBER	DESCRIPTION
1	1	PF 708-10-SK-0689	TRAY, UNDER DESK MOUNT FOR NOKIA ONT-ALCATEL LUCENT-3FE56864AAAA
2	2	CM-PHS-440 X.50-ZI	PAN HEAD MACHINE SCREW-4-40 THREAD X 1/2" LENGTH-ZINC PLATED
3	2	CM-KEP-4-40-ZI	KEP NUT, 4-40,ZINC PLATED
4	4	CM-SMS-PH-#10X.50-ZI	SHEET METAL SCREW-#10 X 1/2"-ZINC PLATED
5	1	VELCRO-1-INCH-BLACK-18	VELCRO STRAP X 1-INCH WIDE X 18" LENGTH

<p>CONFIDENTIAL</p> <p>THIS DRAWING IS THE SOLE PROPERTY OF, AND IS PROPRIETARY TO, CABLE MANAGEMENT SOLUTIONS, INC. THIS DRAWING AND/OR INFORMATION SHALL BE KEPT CONFIDENTIAL, AND MAY NOT BE REPRODUCED, MODIFIED, DISCLOSED, OR MADE AVAILABLE TO OTHERS, WITHOUT THE EXPRESS WRITTEN CONSENT OF SNAKETRAY.</p>	<p>MATERIAL</p> <p>16 GA.CRS OR GALV. STEEL (.060)</p>	<p>ALL TOLERANCES IF NOT INDICATED ARE:</p> <p>FRACTIONS= ± 1/32TH</p> <p>.XX= ± .015</p> <p>.XXX= ± .005</p> <p>ANGULAR= ± 1/2 DEGREE</p>		<p>CABLE MANAGEMENT SOLUTIONS, INC.</p> <p>291 SKIP LANE</p> <p>BAY SHORE, NY 11706</p>
	<p>FINISH</p> <p>POWDERCOAT TCI-BLACK CAT-9210-90663</p>	<p>DRAWN BY</p> <p>E. RENZ</p> <p>DATE</p> <p>7/31/2018</p>		
	<p>PATENTS</p> <p>SNAKETRAY, SNAKE CANYON, WALL SNAKE AND LADDER SNAKE PRODUCTS ARE COVERED BY ONE OR MORE OF THE FOLLOWING PATENTS: #6,637,704, #6,637,165, #6,463,704, #6,460,812, #6,449,912, #6,361,000, #6,347,493, #6,019,323, #5,953,870, #5,839,702 AND AUS #737,813.</p>	<p>TREATMENT</p> <p>NONE</p>	<p>CHECKED BY</p> <p>W.WEST</p> <p>DATE</p> <p>7/31/2018</p>	<p>SIZE</p> <p>D</p>

SCALE	NONE	RELEASE DATE	7/31/2018	SHEET	1 OF 2	REV. NO	B
-------	------	--------------	-----------	-------	--------	---------	---