

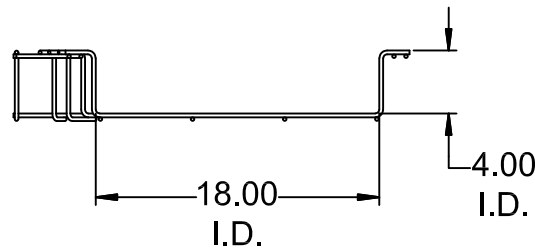

		REVISION		DWG NO:		CM 801-4-18-T	
ZONE	REV	DESCRIPTION	ECN	DATE	APPR	ENGR	
	A	INITIAL RELEASE	10-0000	3/18/2010			

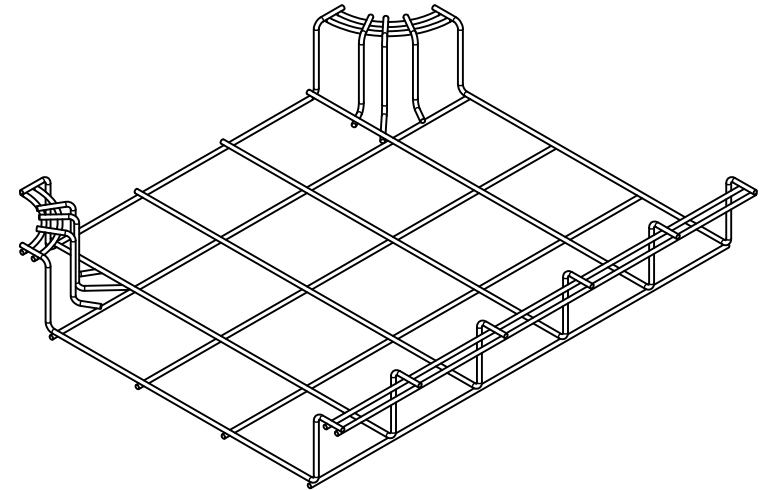
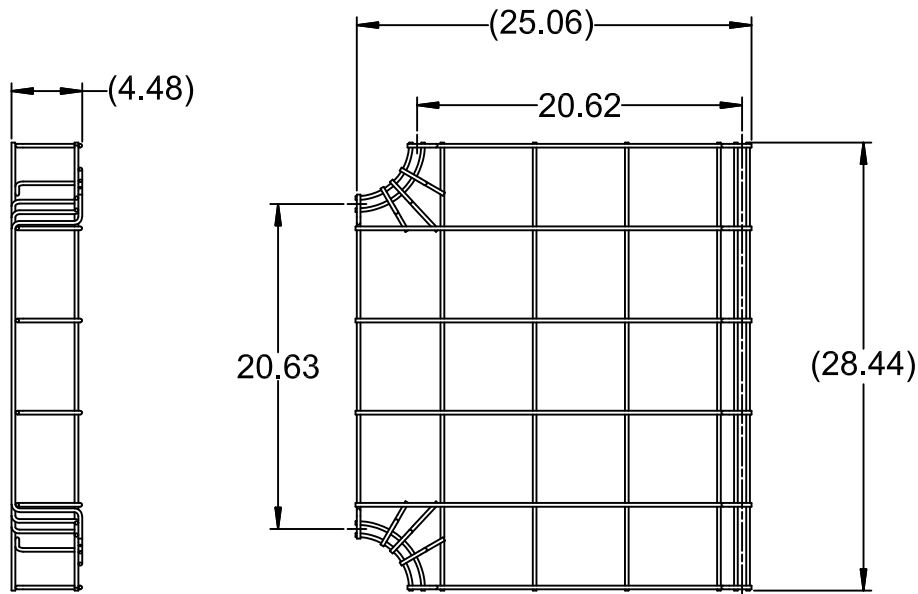

<p>CONFIDENTIAL</p> <p>THIS DRAWING IS THE SOLE PROPERTY OF, AND IS PROPRIETARY TO, CABLE MANAGEMENT SOLUTIONS, INC. THIS DRAWING AND/OR INFORMATION SHALL BE KEPT CONFIDENTIAL, AND MAY NOT BE REPRODUCED, MODIFIED, DISCLOSED, OR MADE AVAILABLE TO OTHERS, WITHOUT THE EXPRESS WRITTEN CONSENT OF SNAKETRAY.</p>	<p>MATERIAL</p> <p>.240 DIA. GALVANIZED WIRE</p>	<p>ALL TOLERANCES IF NOT INDICATED ARE:</p> <p>FRACTIONS= ± 1/32TH</p> <p>.XX= ± .015</p> <p>.XXX= ± .005</p> <p>ANGULAR= ± 1/2 DEGREE</p>	 <p>CABLE MANAGEMENT SOLUTIONS, INC. 291 SKIP LANE BAY SHORE, NY 11706</p>				
	<p>FINISH</p> <p>TBD</p>	<p>DRAWN BY</p> <p>M Rudz</p> <p>DATE</p> <p>11/5/2010</p>		<p>TITLE</p> <p>MEGA SNAKE 4 x 18 T</p>			
<p>PATENTS</p> <p>SNAKETRAY, SNAKE CANYON, WALL SNAKE AND LADDER SNAKE PRODUCTS ARE COVERED BY ONE OR MORE OF THE FOLLOWING PATENTS: #6,637,704, #6,637,165, #6,463,704, #6,460,812, #6,449,912, #6,361,000, #6,347,493, #6,019,323, #5,953,870, #5,839,702 AND AUS #737,815.</p>	<p>TREATMENT</p> <p>NONE</p>	<p>CHECKED BY</p> <p>ENGINEERING</p> <p>DATE</p>	<p>SIZE</p> <p>D</p> <p>SCALE</p> <p>NONE</p>	<p>USED ON</p> <p>CM 801-4-18-T</p> <p>RELEASE DATE</p>	<p>DWG NO</p> <p>CM 801-4-18-T</p>	<p>SHEET</p> <p>1 OF 1</p>	<p>REV. NO</p> <p>A</p>