

Snake Bus® Installation Instructions

Snake Bus® is only for **indoor** use and in dry conditions and is "Acceptable for use in environmental air-handling spaces under raised flooring". The system is pre-wired for different circuit configurations; therefore ensure that system is correct for the application proposed. Each configuration is color and key coded and only components for one color and key are designed to fit together. Floor mounting brackets are incorporated within the track and feed unit for mounting direct to floor slabs. **Do not mount on strut.**

- ◆ Maximum length of **Snake Bus** track is 64ft plus a 10ft tap-off. @ a rated voltage = 120 volts
- ◆ Maximum current overload protection of the track should be by a 50 Amp Type C RCD.
- ◆ Maximum current overload protection of the tap-off should be by a 20 or 30 Amp Type C RCD.
- ◆ Installation to be in accordance with NFPA 70 NEC latest Edition

Feed unit

Determine the run of **Snake Bus** across a level floor in a straight line and arrange for the feed unit entry to be oriented towards the incoming supply.

Remove the dust cover over the key and color coded socket and place at the start of the run of **Snake Bus** with the feed unit entry towards the incoming supply. (Fig1)

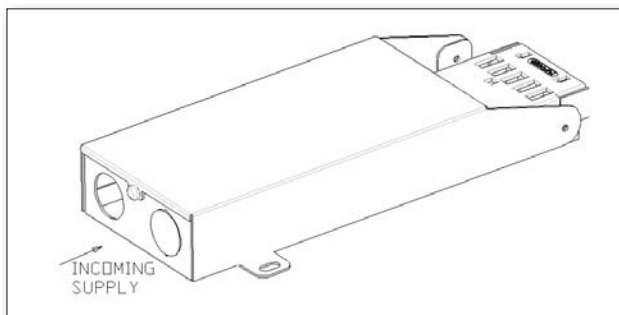

Figure 1

Snake Bus

Remove the protection at the plug end of the **Snake Bus** and insert the plug into the socket on the feed unit confirming the keyway is engaged first. (Fig 2 / Fig 3)

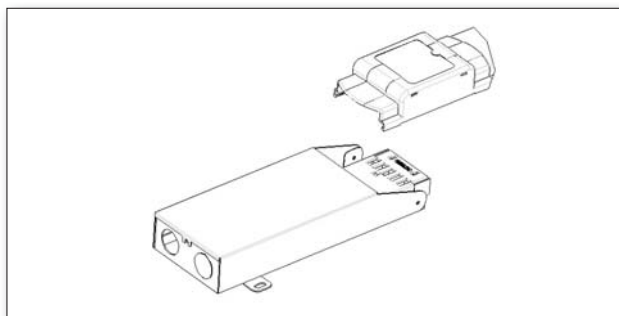

Figure 2

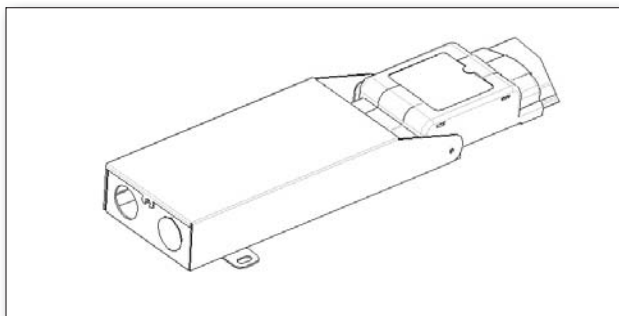

Figure 3

If using continuous lengths clip next length to existing track as previously described. Removing the dust cover on the **Snake Bus** shuttered socket and the protection on the plug of the next length of track, keep repeating until the length of track is complete (Fig 4).

On the final length of **Snake Bus** section the dust cover over the socket **should not** be removed as this offers additional protection to the shuttered socket from dust and dirt.

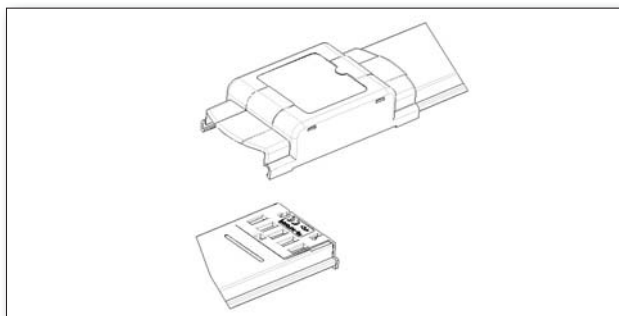

Figure 4

Interlink

When utilizing an Interlink connect the socket to the end of the track by first removing the dust cover on the Snake Bus shuttered socket and the protection on the plug of the male end of the Interlink. Insert the plug into the socket on the Snake Bus ensuring the keyway is engaged first. (Fig 5).

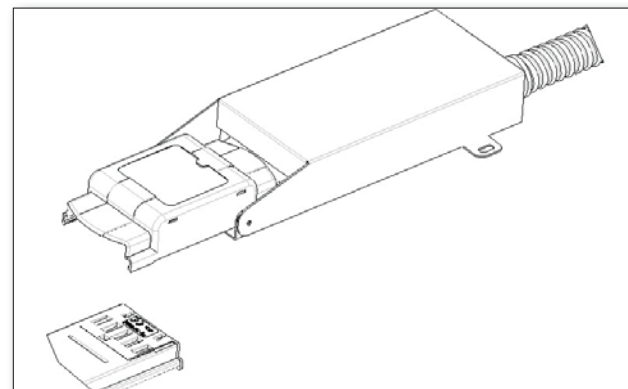

Figure 5

Male interlink

Position the Female Interlink and connect the track as previously described.

Female interlink

On the final length of Snake Bus section the dust cover over the socket should not be removed as this offers additional protection to the shuttered socket from dust and dirt. (Fig 6)

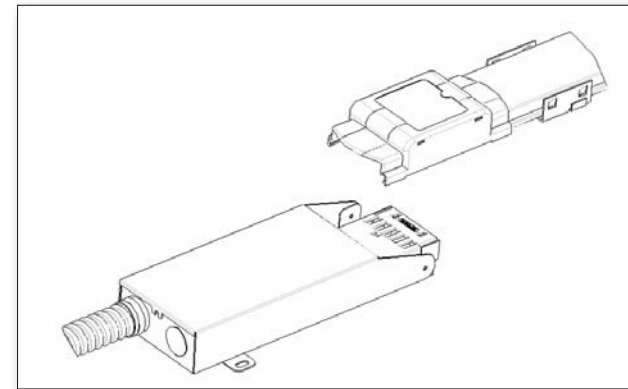

Figure 6

On completion of the of the Snake Bus assembly confirm the position is correct and secure to the floor slab.

Secure the feed unit using suitable anchors via the slots in the base and the track every 4ft. max by the mounting brackets provided along its length (Fig 7). Mount the parts to the floor by suitable means.

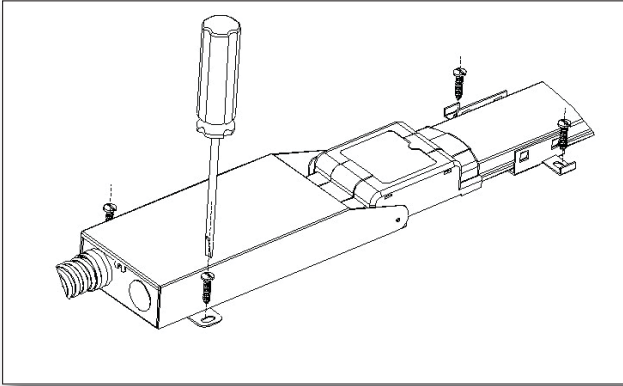

Figure 7

3) Connect the feed unit by inserting the stripped wire into the correct terminal, as shown, see Wiring diagram (Fig 8) and tighten screws

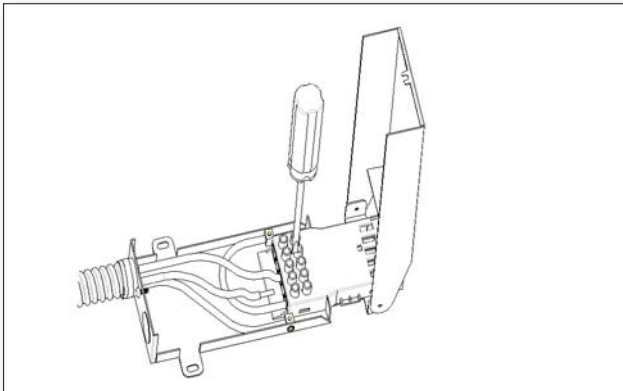
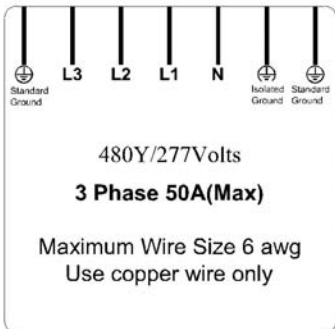

Figure 8



Snake Bus® Installation Instructions



Snake Tray®
291 Skip Lane
Bay Shore NY 11706 USA
T: 800-308-6788 ♦ 631-674-0004
F: 800-881-6641 ♦ 631-674-0010
www.snaketray.com
MADE IN USA

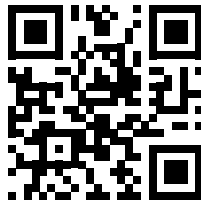

Scan here for
Product Instructions.

Thank you for your Snake Tray Purchase. If you have questions or require additional information, please contact us at 800-308-6788.

Tap-off

WARNING Terminate wiring before inserting tap-off unit plug.

Ascertain the most suitable socket on the Snake Bus for the tap-off, remove the dust cover on the socket and the tap-off plug protection checking for any damage to the contacts. Align the tap-off label to that of the track labels so they are all in the same orientation. Locate the tap-off plug into the socket keyways by slightly pressing in the side legs, and push down keeping the plug square until the two clips on either side of the plug are engaged in the socket and the plug sits on the case. (Fig 9)

Removal of the tap-off plug may be achieved while the system is live but the tap-off is not under load.

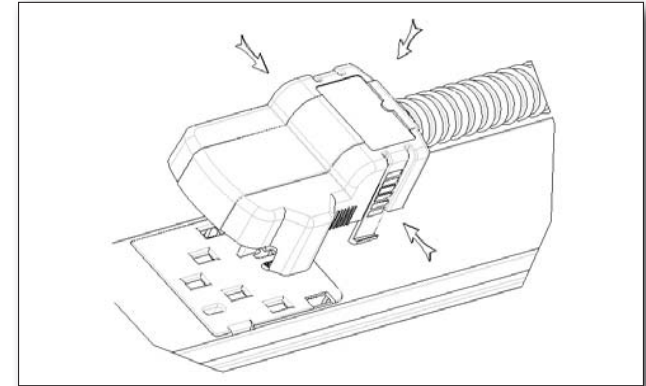

Figure 9

To remove tap-off push down on top of tap-off, push in side legs at the same time, then withdraw the tap-off (Fig 10)

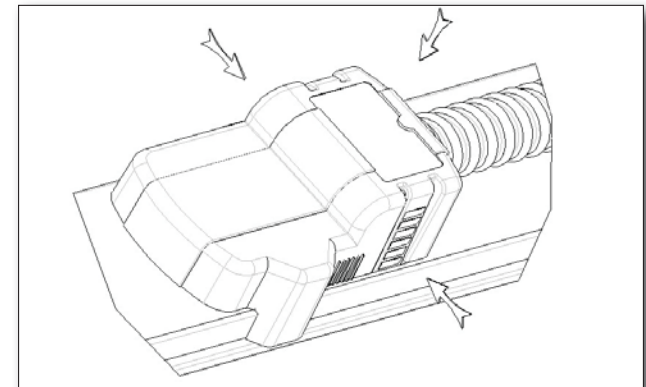

Figure 10