

8 7 6 5 4 3 2 1

DWG NO: CM101-4-21-8-R6

ZONE		REV	DESCRIPTION	ECN	DATE	APPROVE	ENGINE
		A	INITIAL RELEASE	10-0000	3/1/2010	RJ	WW

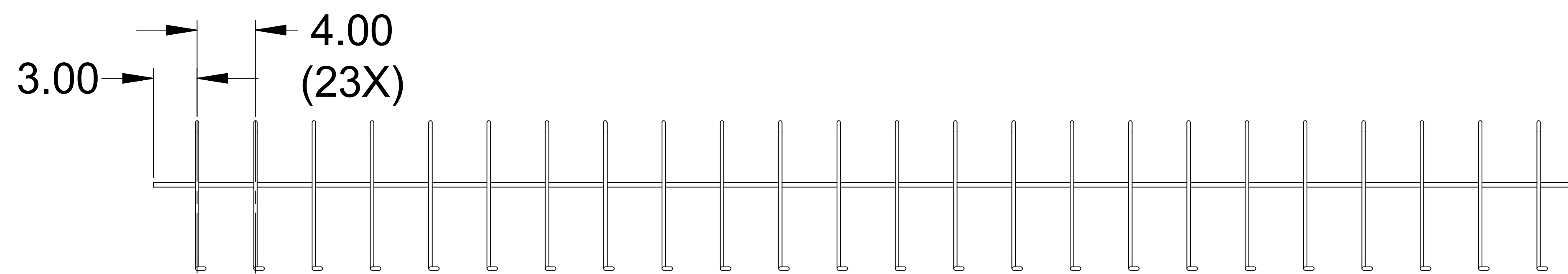
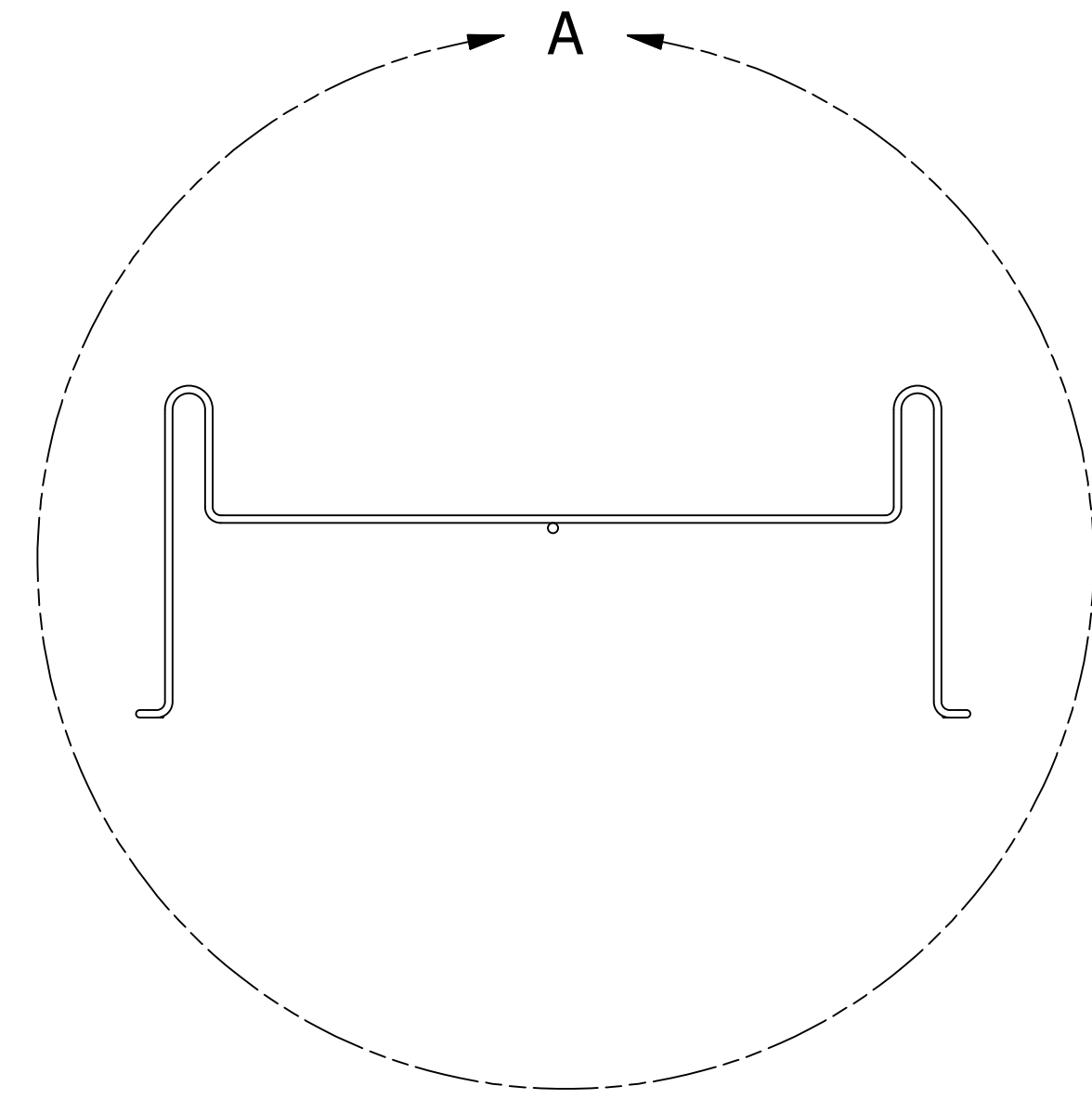
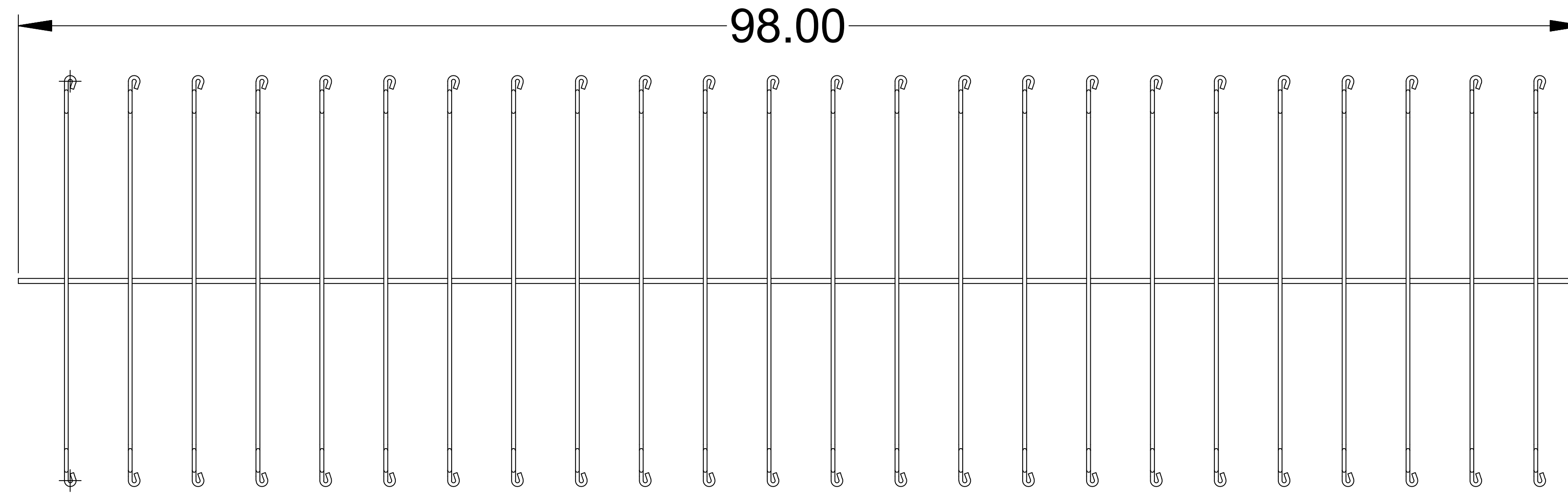
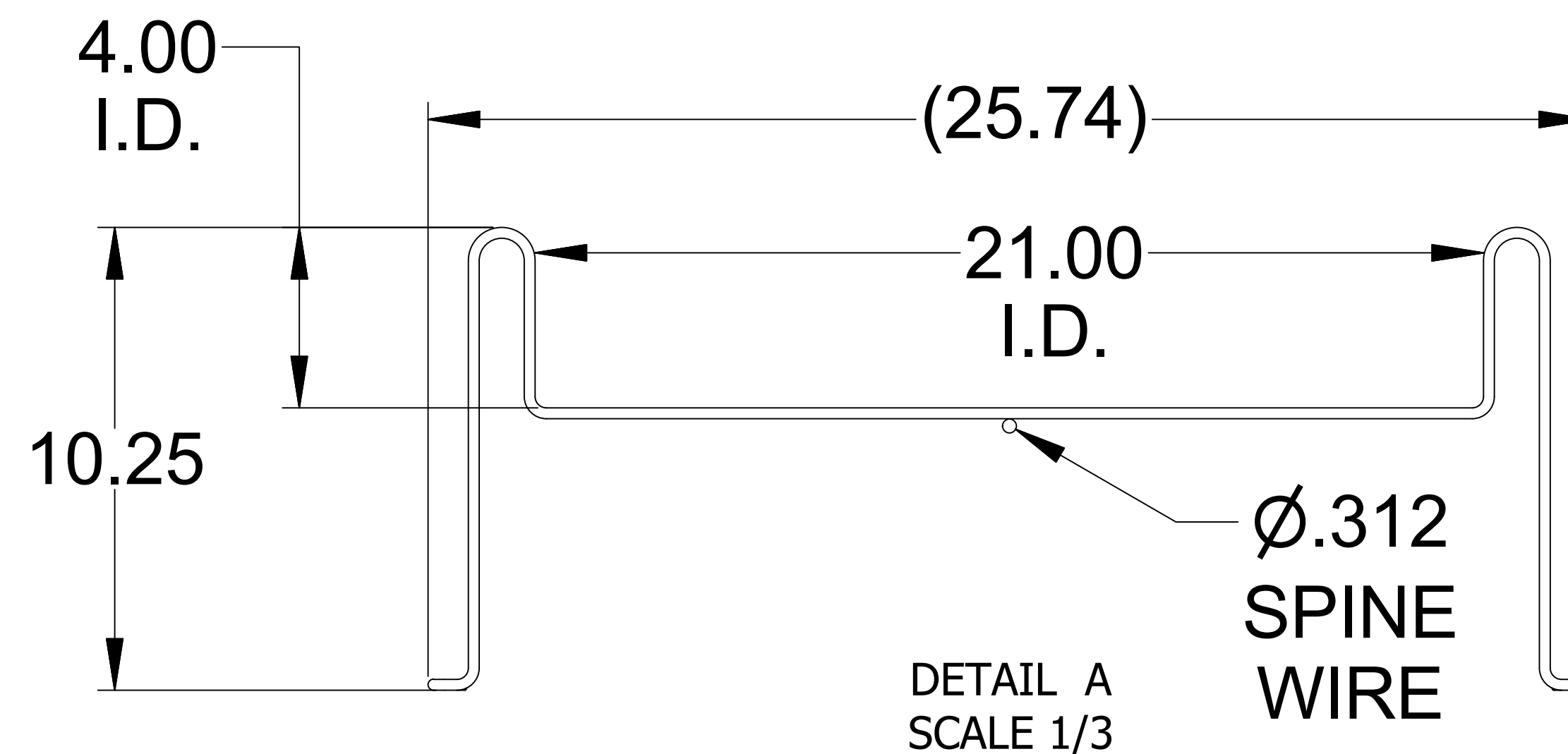
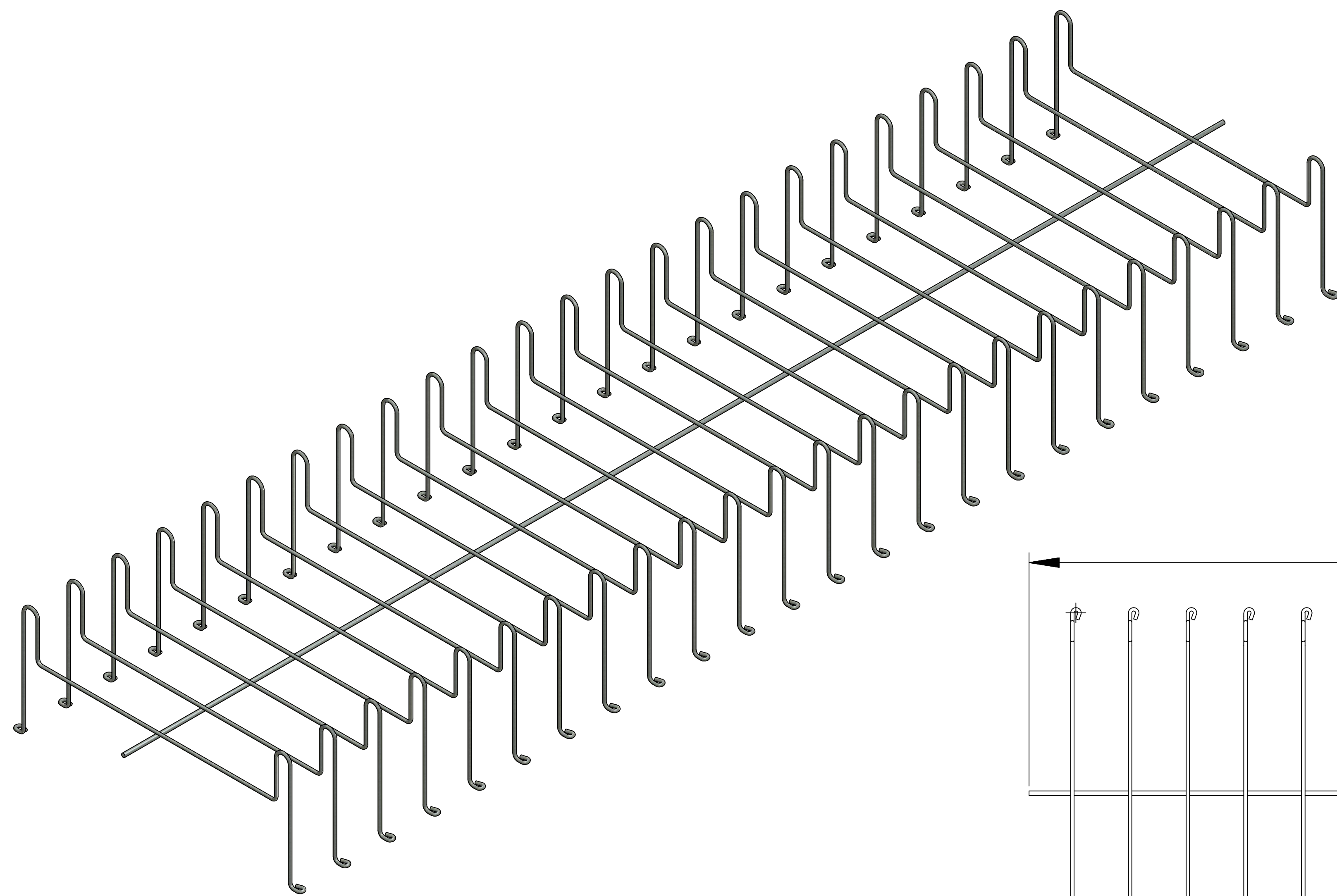

<p>CONFIDENTIAL THIS DRAWING IS THE SOLE PROPERTY OF, AND IS PROPRIETARY TO, CABLE MANAGEMENT SOLUTIONS, INC. THIS DRAWING AND/OR INFORMATION SHALL BE KEPT CONFIDENTIAL, AND MAY NOT BE REPRODUCED, MODIFIED, DISCLOSED, OR MADE AVAILABLE TO OTHERS, WITHOUT THE EXPRESS WRITTEN CONSENT OF SNAKETRAY.</p>	MATERIAL	ALL TOLERANCES IF NOT INDICATED ARE: FRACTIONS= ± 1/32TH .XX= ± .015 .XXX= ± .005 ANGULAR= ± 1/2 DEGREE		<p>CABLE MANAGEMENT SOLUTIONS, INC. 291 SKIP LANE BAY SHORE, NY 11706</p>																				
	GALVANIZED	FINISH	<table border="1"> <tr> <td>DRAWN BY</td> <td>DATE</td> </tr> <tr> <td>W. WEST</td> <td>3/1/2010</td> </tr> <tr> <td>CHECKED BY</td> <td>DATE</td> </tr> <tr> <td>E. RENZ</td> <td>10/13/2011</td> </tr> <tr> <td>ENGINEERING</td> <td>DATE</td> </tr> <tr> <td>R. JETTE</td> <td>10/13/2011</td> </tr> </table>		DRAWN BY	DATE	W. WEST	3/1/2010	CHECKED BY	DATE	E. RENZ	10/13/2011	ENGINEERING	DATE	R. JETTE	10/13/2011								
DRAWN BY	DATE																							
W. WEST	3/1/2010																							
CHECKED BY	DATE																							
E. RENZ	10/13/2011																							
ENGINEERING	DATE																							
R. JETTE	10/13/2011																							
<p>PATENTS SNAKETRAY, SNAKE CANYON, WALL SNAKE AND LADDER SNAKE PRODUCTS ARE COVERED BY ONE OR MORE OF THE FOLLOWING PATENTS: #6,637,704, #6,637,165, #6,463,704, #6,460,812, #6,449,912, #6,361,000, #6,347,493, #6,019,323, #5,953,870, #5,838,776 AND #737,813.</p>	TREATMENT	<table border="1"> <tr> <td>TITLE:</td> <td colspan="2">101 SERIES FLOOR MOUNT TRAY, 4"x 21", 6" UNDER-CLEARANCE</td> </tr> <tr> <td>SIZE</td> <td>USED ON</td> <td>DWG NO</td> </tr> <tr> <td>D</td> <td>101 SERIES</td> <td>CM101-4-21-8-R6</td> </tr> <tr> <td>SCALE</td> <td>RELEASE DATE</td> <td>SHEET</td> </tr> <tr> <td>NONE</td> <td></td> <td>1 OF 1</td> </tr> <tr> <td></td> <td></td> <td>REV. NO</td> </tr> <tr> <td></td> <td></td> <td>A</td> </tr> </table>		TITLE:	101 SERIES FLOOR MOUNT TRAY, 4"x 21", 6" UNDER-CLEARANCE		SIZE	USED ON	DWG NO	D	101 SERIES	CM101-4-21-8-R6	SCALE	RELEASE DATE	SHEET	NONE		1 OF 1			REV. NO			A
TITLE:	101 SERIES FLOOR MOUNT TRAY, 4"x 21", 6" UNDER-CLEARANCE																							
SIZE	USED ON	DWG NO																						
D	101 SERIES	CM101-4-21-8-R6																						
SCALE	RELEASE DATE	SHEET																						
NONE		1 OF 1																						
		REV. NO																						
		A																						

8 7 6 5 4 3 2 1