

|          |     |                 |     |           |          |
|----------|-----|-----------------|-----|-----------|----------|
| DWG NO:  |     | CM 0312         |     |           |          |
| REVISION |     |                 |     |           |          |
| ZONE     | REV | DESCRIPTION     | ECN | DATE      | APPROVED |
|          | A   | INITIAL RELEASE |     | 3/22/2010 | ENGINEER |

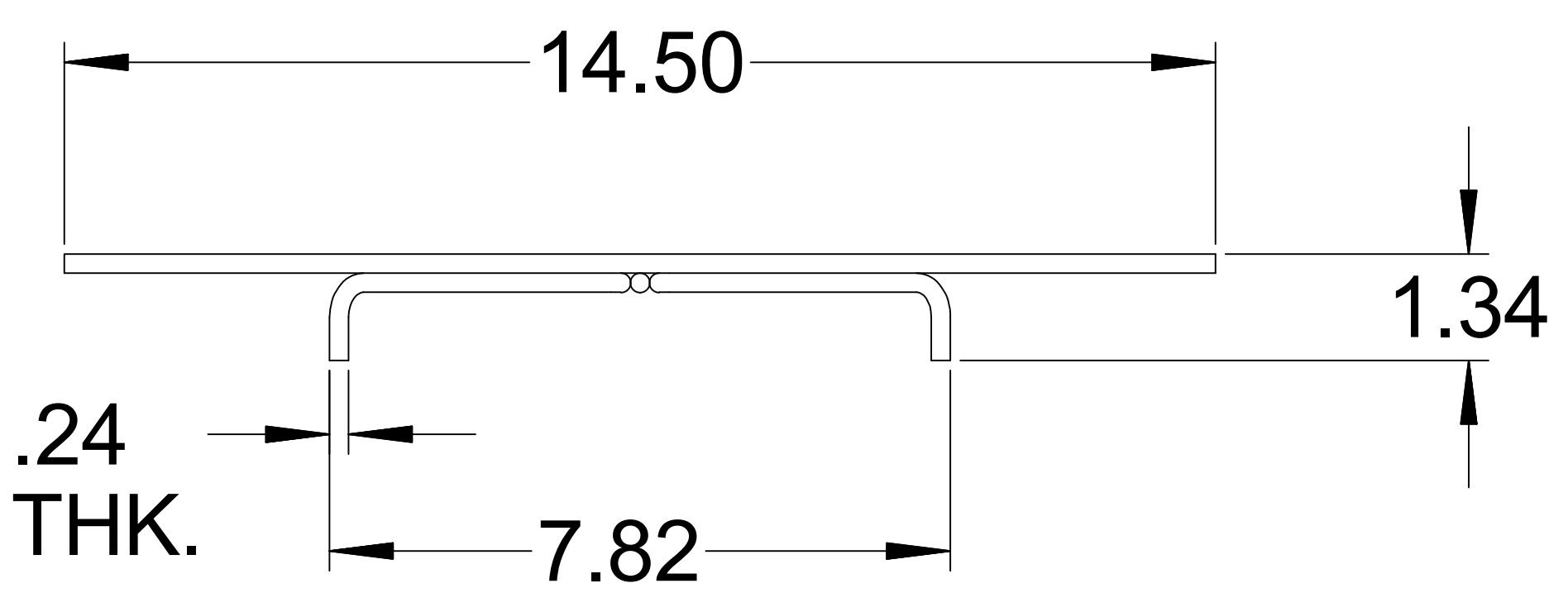
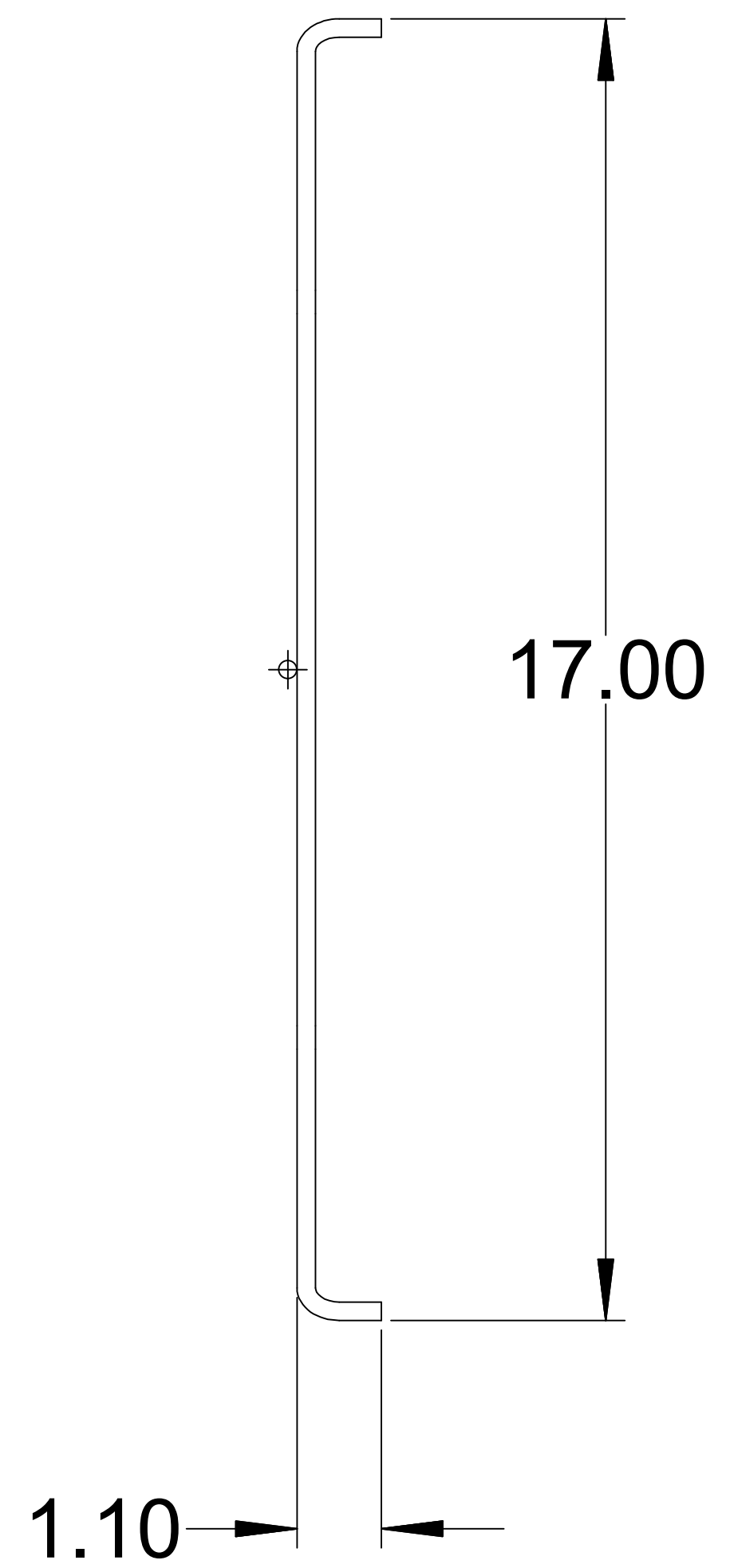
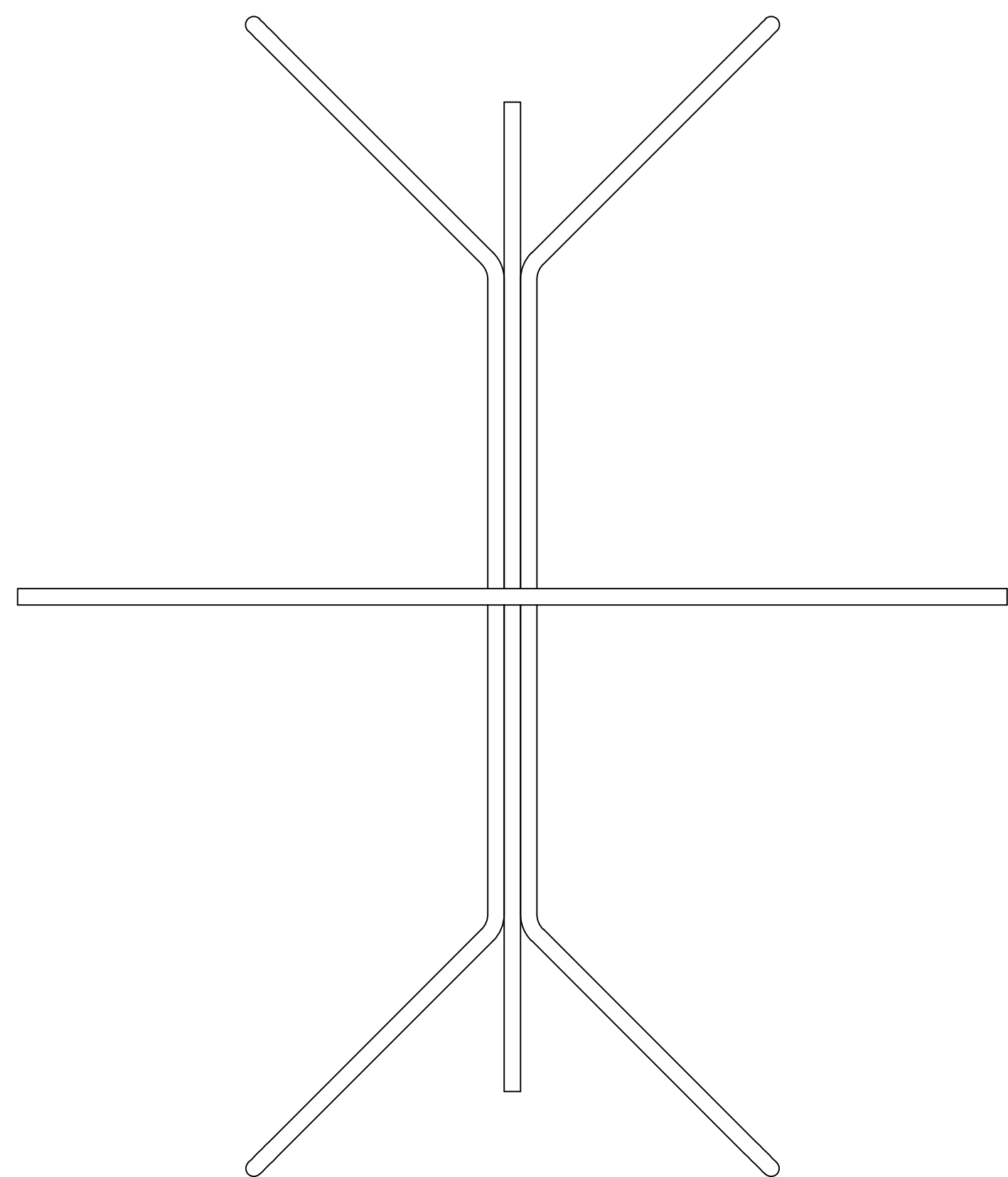
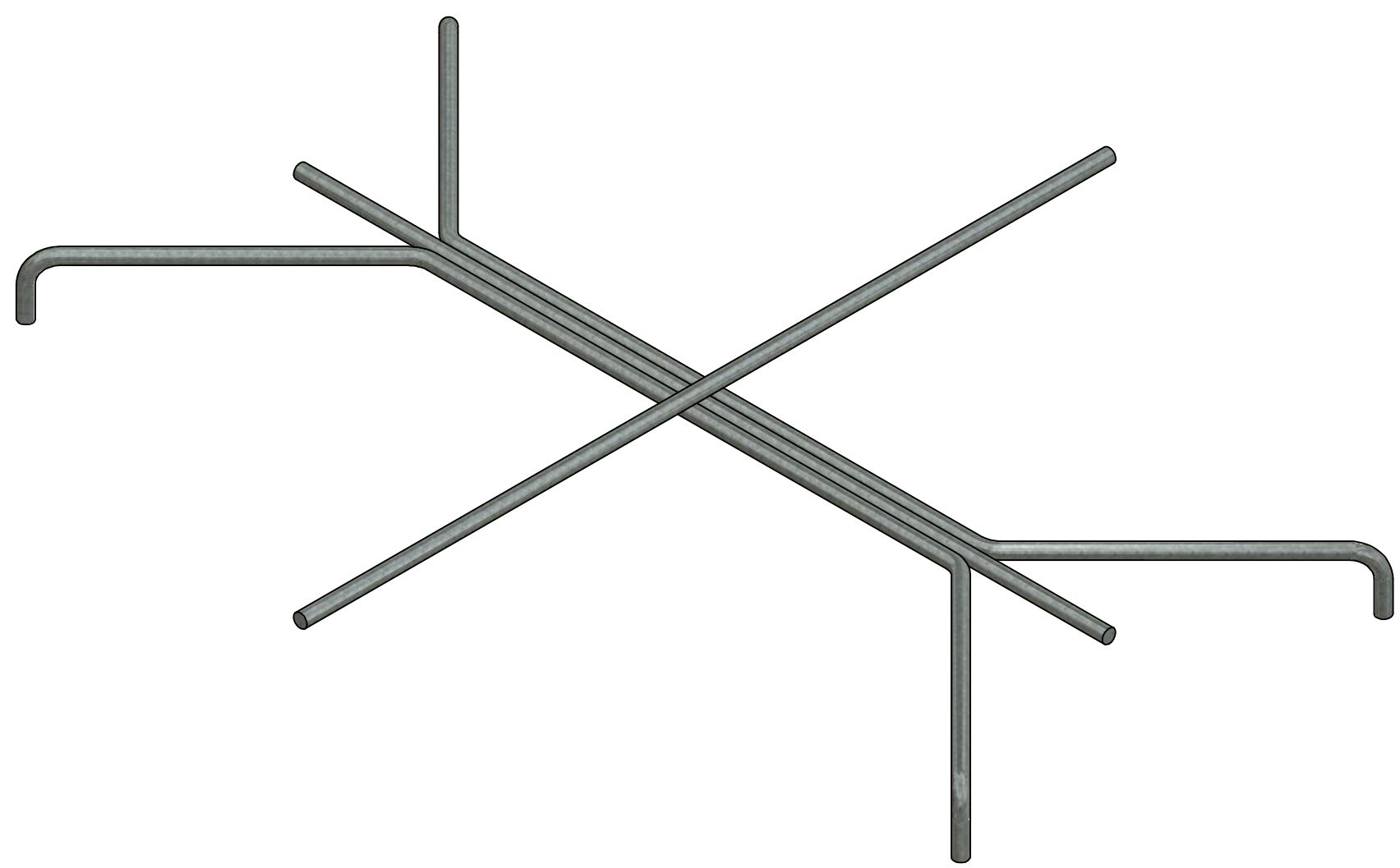

**CONFIDENTIAL**  
 THIS DRAWING IS THE SOLE PROPERTY OF, AND IS PROPRIETARY TO, CABLE MANAGEMENT SOLUTIONS, INC. THIS DRAWING AND/OR INFORMATION SHALL BE KEPT CONFIDENTIAL, AND MAY NOT BE REPRODUCED, MODIFIED, DISCLOSED, OR MADE AVAILABLE TO OTHERS, WITHOUT THE EXPRESS WRITTEN CONSENT OF SNAKETRAY.

**PATENTS**  
 SNAKETRAY, SNAKE CANYON, WALL SNAKE AND LADDER SNAKE PRODUCTS ARE COVERED BY ONE OR MORE OF THE FOLLOWING PATENTS: #6,637,704, #6,637,165, #6,463,704, #6,460,812, #6,449,912, #6,361,000, #6,347,493, #6,019,323, #5,953,870, #5,839,702 AND AUS #737,813.

|           |            |  |
|-----------|------------|--|
| MATERIAL  | GALVANIZED |  |
| FINISH    | -          |  |
| TREATMENT | NONE       |  |

|  |            |
|--|------------|
| ALL TOLERANCES IF NOT INDICATED ARE:<br>FRACTIONS= ± 1/32TH<br>.XX= ± .015<br>.XXX= ± .005<br>ANGLULAR= ± 1/2 DEGREE |            |
| DRAWN BY   | DATE       |
| W. WEST  | 3/22/2010  |
| CHECKED BY   | DATE       |
| E. RENZ  | 10/14/2011 |
| ENGINEERING  | DATE       |
| R. JETTE   | 10/14/2011 |



**CABLE MANAGEMENT SOLUTIONS, INC.**  
 291 SKIP LANE  
 BAY SHORE, NY 11706

|   |              |         |
|---|--------------|---------|
| TITLE:<br>101 SERIES INTERSECTION, 3" X 12" |              |         |
| SIZE  | USED ON      | DWG NO  |
| D   | 101 SERIES   | CM 0312 |
| SCALE                                       | RELEASE DATE | SHEET   |
| NONE  |              | 1 OF 1  |
|   |              | REV. NO |
|   |              | A       |